

3-phase output
on 3ph-AC-network

3-phase frequency inverter
on 3ph-network 230V / 400V AC

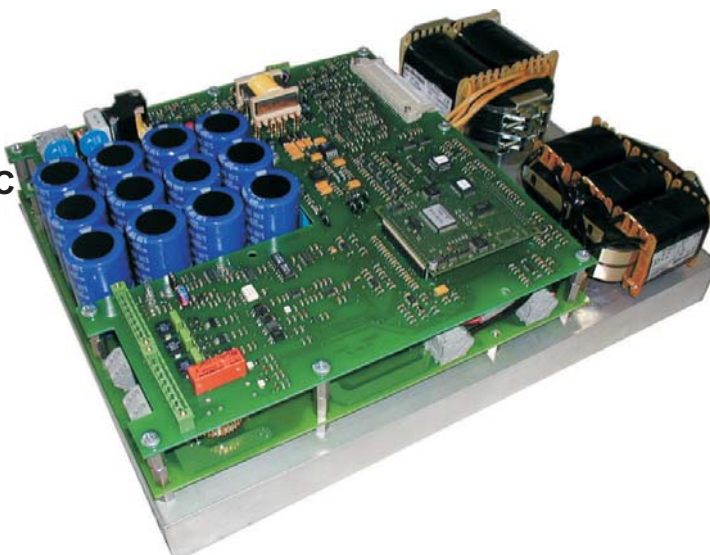

- Use on mobile 3Ph-400V-networks
- Synthetic 3-Ph sine wave output
- With f/U-control and I²t-monitoring
- Input and Output radio interf. adapted
- Low rated air ventilation from T_u >50°C
- Efficiency typ. 93%
- No peak-value rectifying
- RS 232 / 485 Interface for changes of parameters and data check



© registered trademark of company SYKO GmbH & Co. KG

Series FUR 02

without isolation

Main points:

Input:

- 3Ph-sine/rectangular/trapeze-voltage
- External fuse (emergency protection)
- Disturbance proof EN61000-4-4/5 level 3
- Input filter in acc. to EN55011.A+20db
- Soft start / internal pre-charging (semiconductor)
- Controlled bridge input
- Inrush current limiting to UZK
- Integral power run-up (df/dt)
- Defined switch-on/switch-off point
- No-load power on request
- Plug: Wago Cage Clamp 4mm²

Output

- 3Ph-sine voltage
- Internal output EMC-filter
- f/U-characteristic curve (zero up to max)
- I²t-over load protection of dynamical loads
- No-load proof, short circuit proof dynamically and statically
- Tolerance ± 6% = f(U_{in}/I_{out}/T_U)
- Response time ΔI=50% < 2 ms
- Distortion factor <x%
- Under voltage control = f(U_{set point})
- Plug: Wago Cage Clamp 4mm²

In general:

- Signal connector: Phoenix plug 2,5mm²
- On/Off remote (Inhibit)
- Failure signal U_{out}
- Status display LED UH okay
- Temperature control
- Boost-UZK-inverter
- Clock frequency >10 kHz
- Isolation test voltage:
Input/Output - ground: 2,5 KV_{AC} 1 min
- Ambient temperature -25°C / +70°C
- Short term 85°C / Derating 2%/°C >60°C (ventilation to be clarified)
- MTBF on request
- Shock/vibration in acc. to EN50155
- Weight: approx. 17 kg
- Dimension: (420 x 300 x 120)mm
no external application circuit
- CE-Conformity on request

Input

U_{in} / 3Ph
Vrms

360 - 480 V AC

50/60Hz

400V-3ph-network

82 - 160 V AC

50/60Hz

115V-3ph-network

Output

U_{out} / 3Ph P_{out} stat./dyn. Model
Vrms VA number

230 4000/6000 FUR02.U400.230.400/600

400 4000/6000 FUR02.U400.400.400/600

115 2000/3000 FUR02.U115.115.200/300

230 2000/3000 FUR02.U115.230.200/300

The output voltage can drop up to 10% by U_{in} min

Mechanical adaptation: On request

One time projecting costs: On request

Modification costs for possible changes above values: On request

An isolation is possible with an external transformer

Efficiency

On request

3ph-frequency inverters of the **FUR 02** series have been designed for the use in rolling stock/railway and ship applications for the controlled supply of 3ph-motors with dynamical run-up of compressors, fans, dryers, pumps and tools etcetera out of a fixed 3ph-network.

The 400V/3Ph/50Hz input voltage U_{in} is put on the intermediate capacitors with a soft start over a diode-resistor combination to UZK2. After the charging of these high quality capacitors, monitoring of the voltage amplitude and a delay the controlled thyristor-diode 3ph-bridge is activated to bridge the high resistive pre-charging-circuit. The thyristors are switched network-synchron with 120° phase difference each. Negative supplies at the thyristor in this way prevent high power losses. At the same time the Booster is activated. The nested U/I-control loop (voltage control loop with subordinated current control loop) for the short circuit limitation and charging to the charging-end-voltage (UZK2) works with an average-current-mode and not with an interference susceptible pear-current-regulation. With this solution the Booster's frequencies and the 3ph-bridge can work together un-synchronized unproblematically. The Boost-choke is a low frequency-choke that the single phase current is a 120° rectangular current (a peak current through rectifying to capacitors with extreme amplitudes and a low operating current angle is prevented). The Boost-circuit is short circuit protected and under/over voltage is monitored. To filter the HF-content and to keep the EMC-requirements a 3ph-filter is used input sided. The subordinated power block to generate the 3-phase with a higher voltage of 480Vrms and up to 60Hz works with an isolated application for the processor, monitoring and power-control. An external auxiliary voltage must be available.

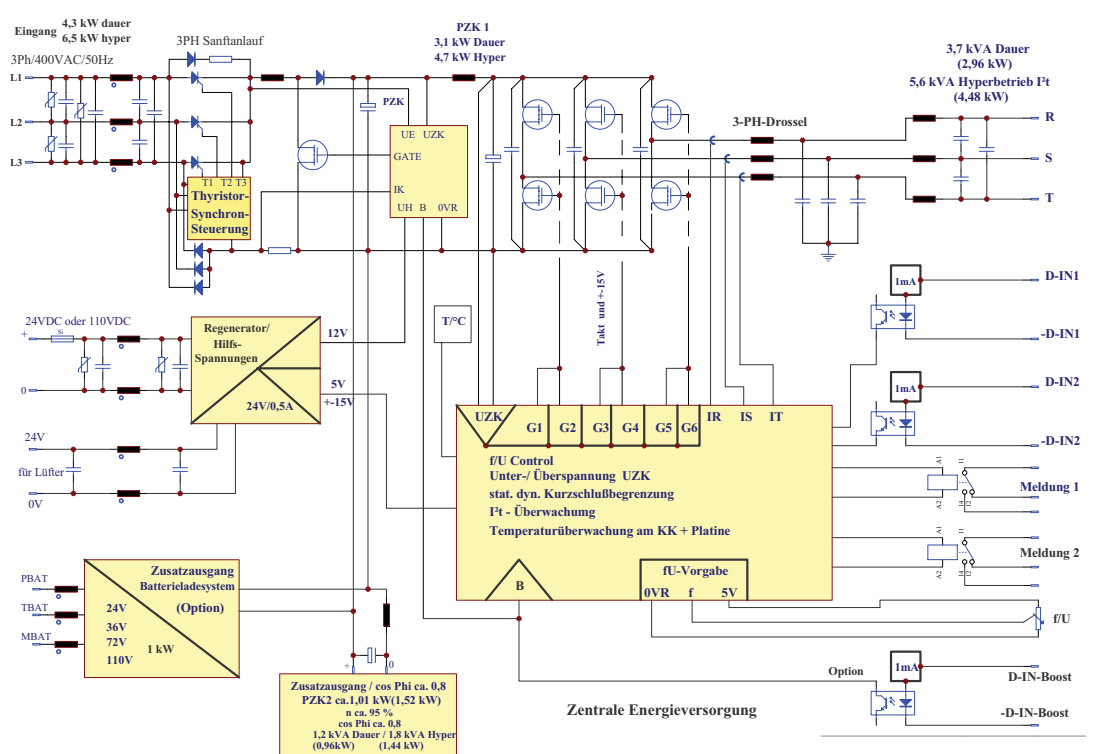

monitoring of the voltage amplitude and a delay the controlled thyristor-diode 3ph-bridge is activated to bridge the high resistive pre-charging-circuit. The thyristors are switched network-synchron with 120° phase difference each. Negative supplies at the thyristor in this way prevent high power losses. At the same time the Booster is activated. The nested U/I-control loop (voltage control loop with subordinated current control loop) for the short circuit limitation and charging to the charging-end-voltage (UZK2) works with an average-current-mode and not with an interference susceptible pear-current-regulation. With this solution the Booster's frequencies and the 3ph-bridge can work together un-synchronized unproblematically. The Boost-choke is a low frequency-choke that the single phase current is a 120° rectangular current (a peak current through rectifying to capacitors with extreme amplitudes and a low operating current angle is prevented). The Boost-circuit is short circuit protected and under/over voltage is monitored. To filter the HF-content and to keep the EMC-requirements a 3ph-filter is used input sided. The subordinated power block to generate the 3-phase with a higher voltage of 480Vrms and up to 60Hz works with an isolated application for the processor, monitoring and power-control. An external auxiliary voltage must be available.

Mechanics

